

KPIT

Model Based Development Approach –
AUTOSAR + Functional Safety + Aspice

Nishant Tholiya

AVP & Business Leader – Automotive Product Engineering Services

KPIT Industry Focused Solutions



**Automotive &
Transportation**



Manufacturing



Energy & Utilities

KPIT = Product Engineering & Enterprise IT

Embedded Software | Product & Engineering Design | IT Platforms & Solutions

Process modernization using IT | Cloud & Big Data Analytics | PLM | Digital Transformation | Infrastructure Management Solutions

Automotive and Allied Engineering - Snapshot

Product Engineering to make mobility **Smarter, greener, safer & affordable**

10SEP2013

Product Engineering Solutions Across



Products Business Portfolio

Tools

Products

K-SAR
AUTOSAR Suite

Worlds' FIRST AUTOSAR R 4.0.3 Solution
RTE | Basic Software Stack | MCAL

In2Soft Diagnostic Tools

ODX Designer | OTX Suite | Diagnostic IDE/RTE

BMS

Battery Management Systems
Automotive | Stationary Applications

KIVI

KPIT In Vehicle Infotainment Platform

REVOLO[®]
hybrid solution for everyone

Plug In Parallel Hybrid Solution

People with passion for Technology
4500+

OEMs & Tier 1s who benefit from our technology
85+

Vehicle Production Programs impacted by us
350+

Total number of projects executed
2000+

The Global Automotive Industry is in a Transformational phase....



Electrification & Fuel Efficiency

Electric vehicles to be **35%** of global new car sales by 2040
Various Geos offers imperatives and constraints for Electric vehicle adoptions



Connectivity

89% of new cars sold worldwide will have embedded connectivity by 2024



Autonomous Driving

10 Million Self-Driving Cars Will Be On The Road By 2020



Consumer Experience

Vehicle **customization, ride sharing, personalization, multi modal** transport considered game changers by Automotive industry

We are moving towards the world of Autonomous, Connected, Fuel Efficient, Lightweight vehicles with personalized Consumer Experience

Future trends imposing technical need of standard compliance and change in development workflow



Technical Needs



Functional Safety



Platform strategies



Development Needs

Model based system and software engineering

Autosar Platform approach

Integrated model based development environment

KPIT' Feature Development MBD workflow: Focus on 'Continuous Verification'

Compliant to ISO26262, ASPICE and Autosar standards

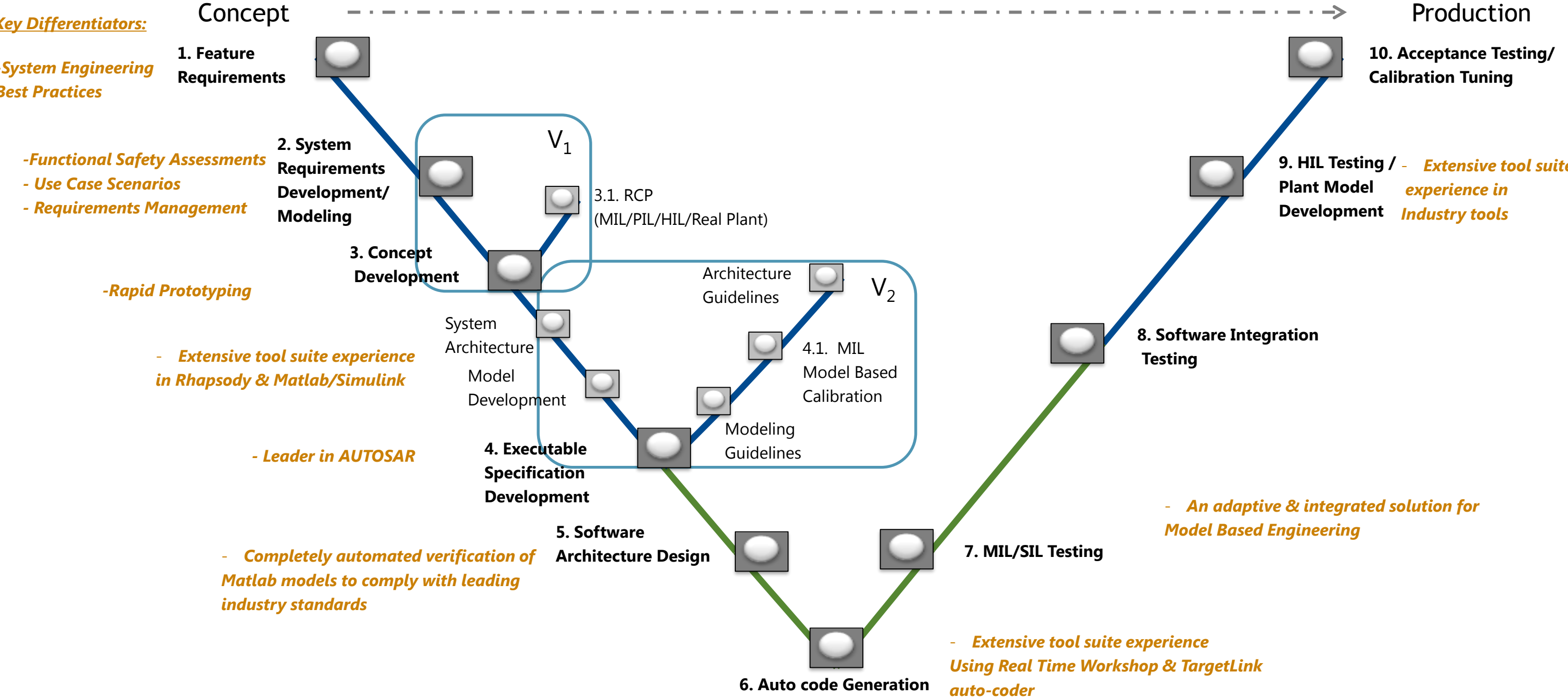

Functional Safety Lifecycle – KPIT Involvement

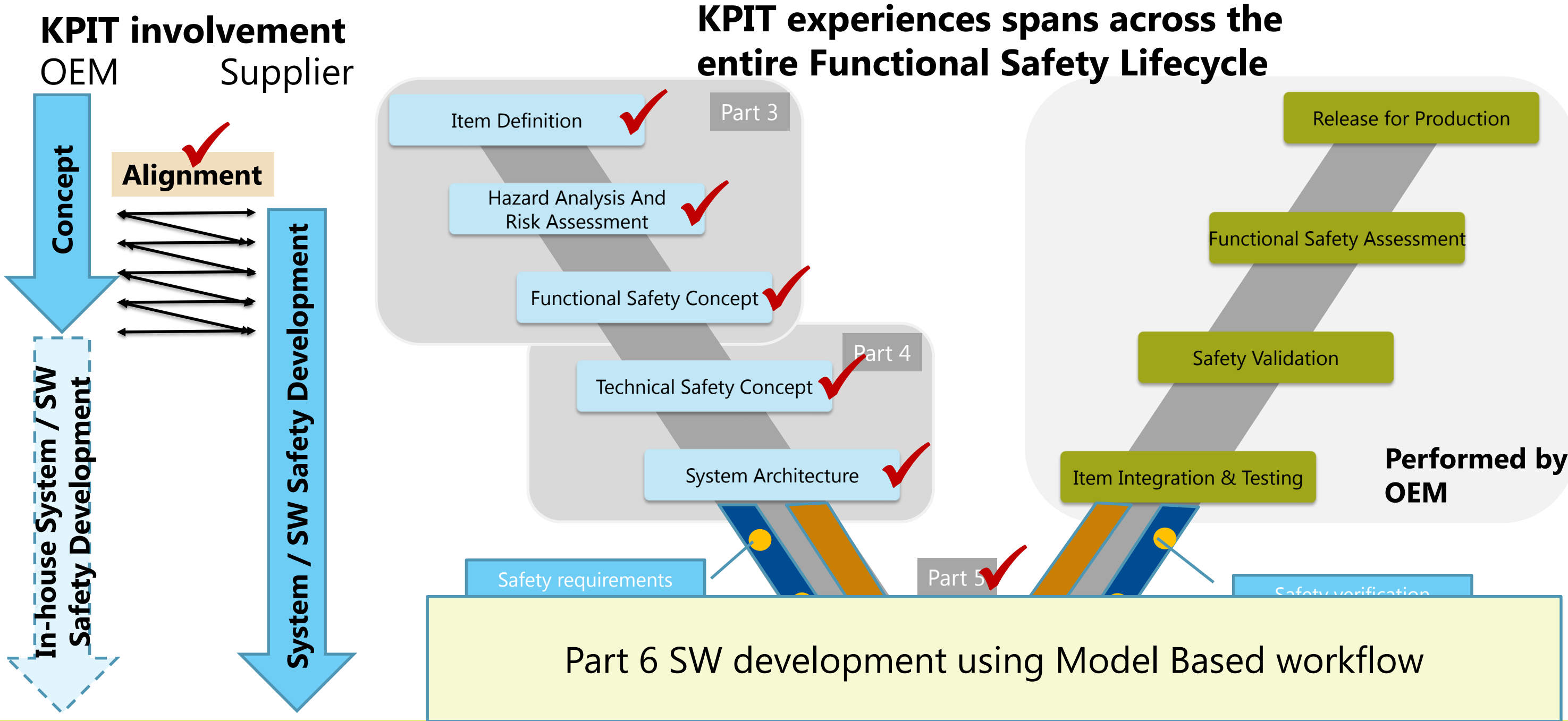

ISO26262: Part 6 : REQUIREMENTS & METHODS

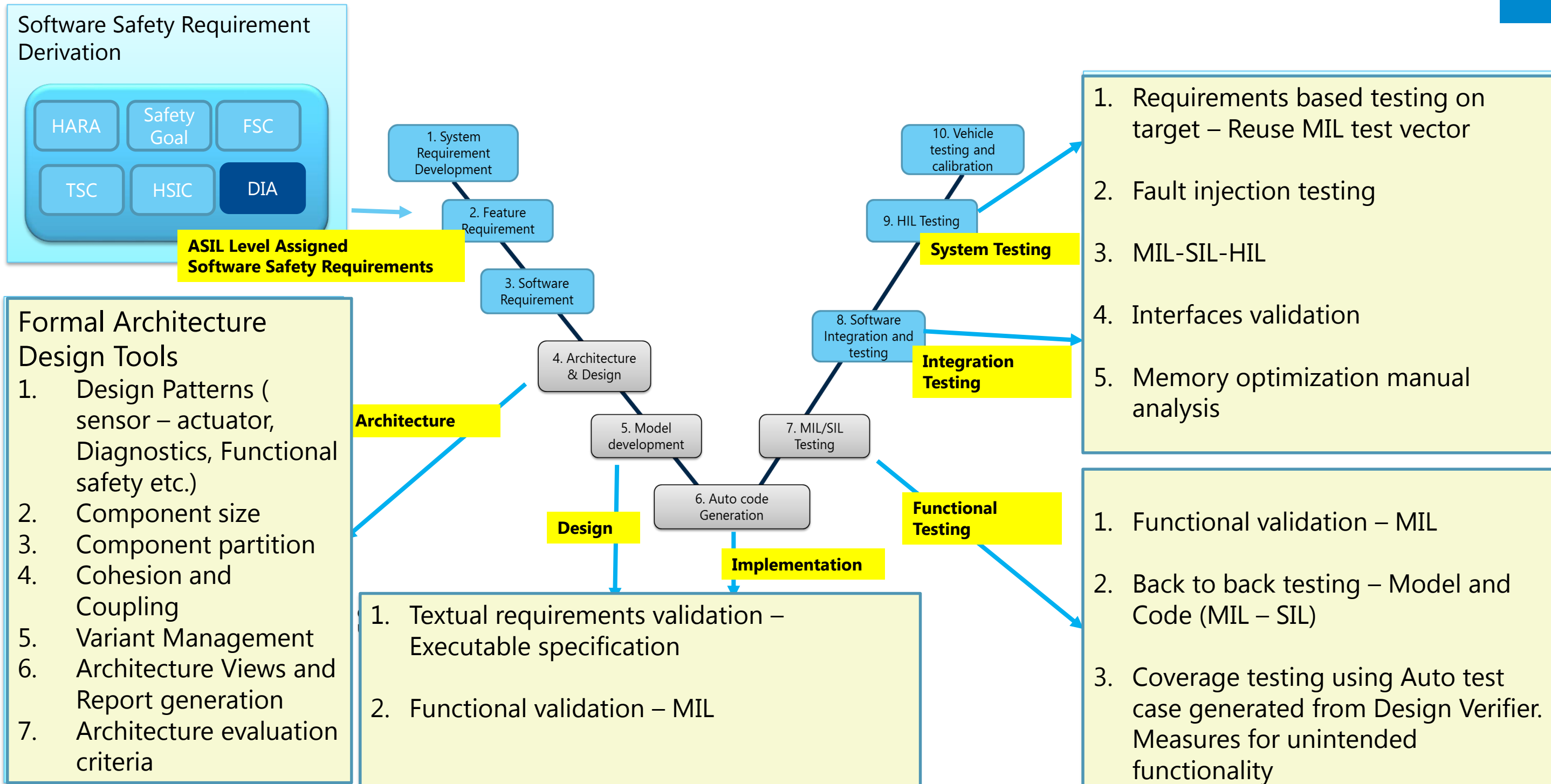

Motivation & Implications of migrating to AUTOSAR

Main motivation to migrate from the legacy software is to manage the increasing complexity of the increasing electronics and software complexity and at the same time:

- Improve quality
- Reduce cost
- Reduce time to market

Typical challenges when migrating from the legacy software to AUTOSAR

- Software migration & complexity
- Variants management
- Configurator vs. implementer
- New technologies

Software migration & complexity

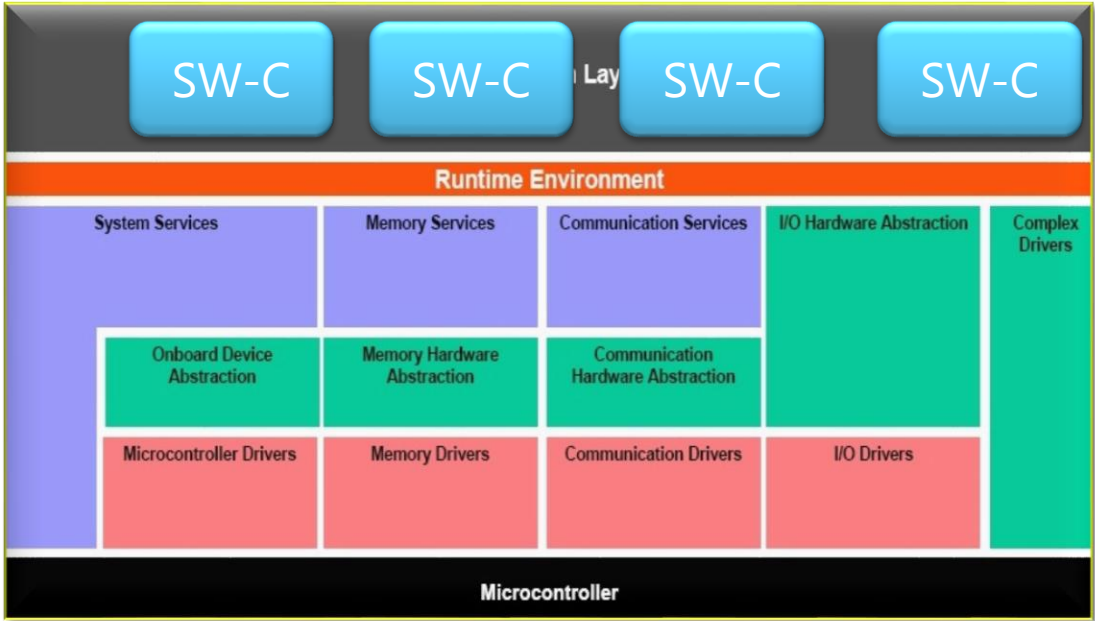
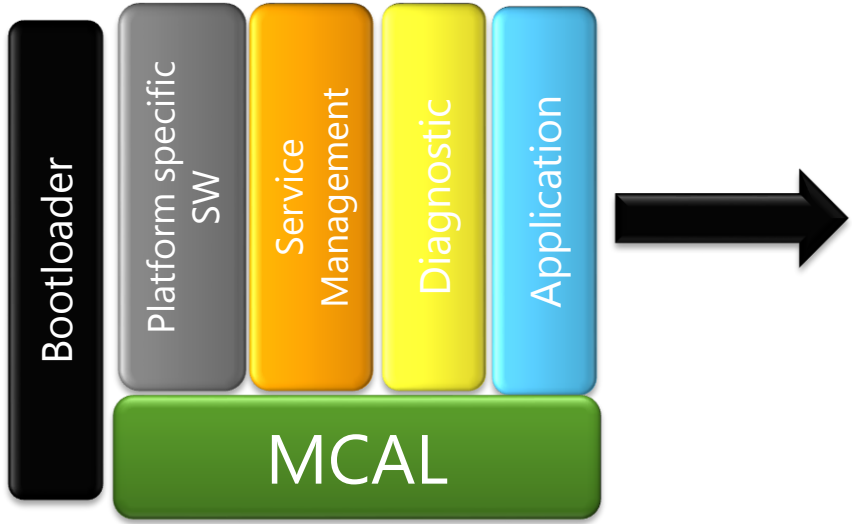

- Application Migration
- Application integration with BSW
- BSW License – delivered pre-integrated with MCAL
- Diagnostics integration and configuration

- BSW configuration → Most services are available in AUTOSAR
- Project specific complex drivers and I/O abstraction
- Bootloader integration
- SWC unit testing and Rapid Prototyping

Workflow of AUTOSAR Application Migration using MBD

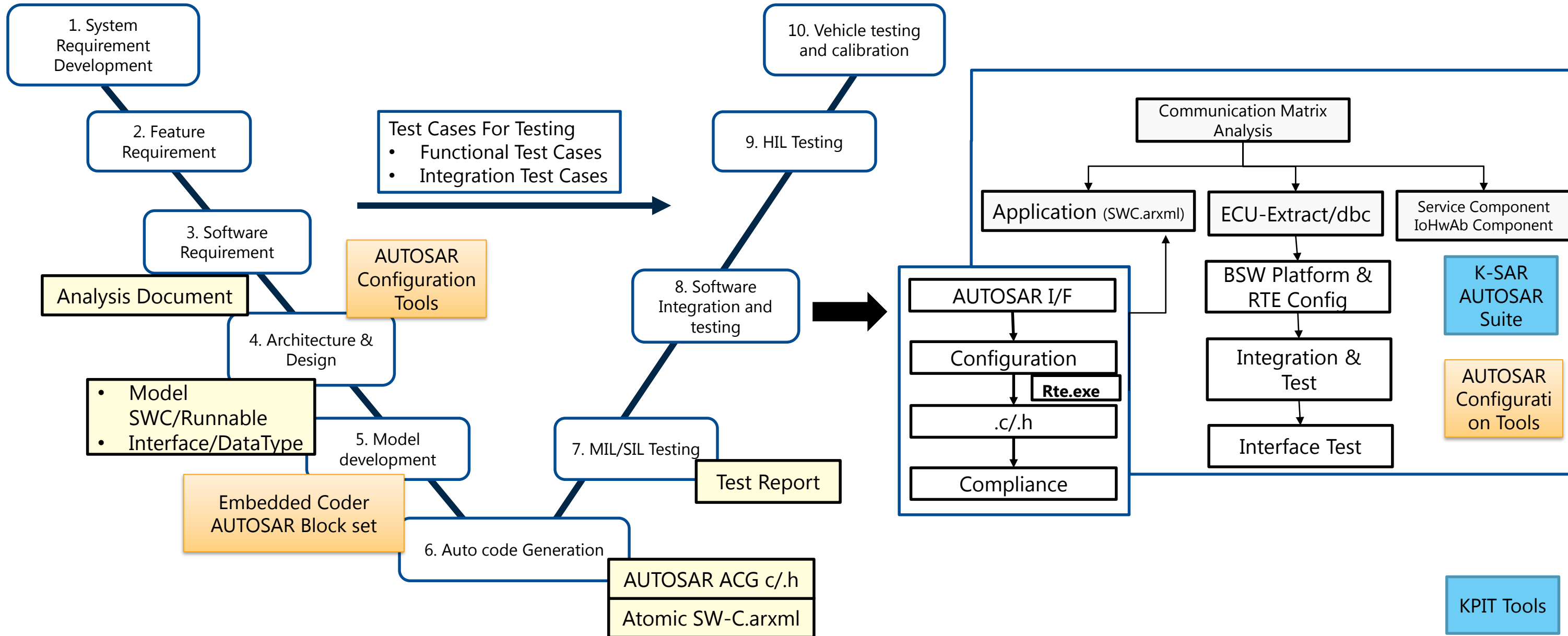

Round trip approach –AUTOSAR Compliant Development

1 Create AUTOSAR Architecture

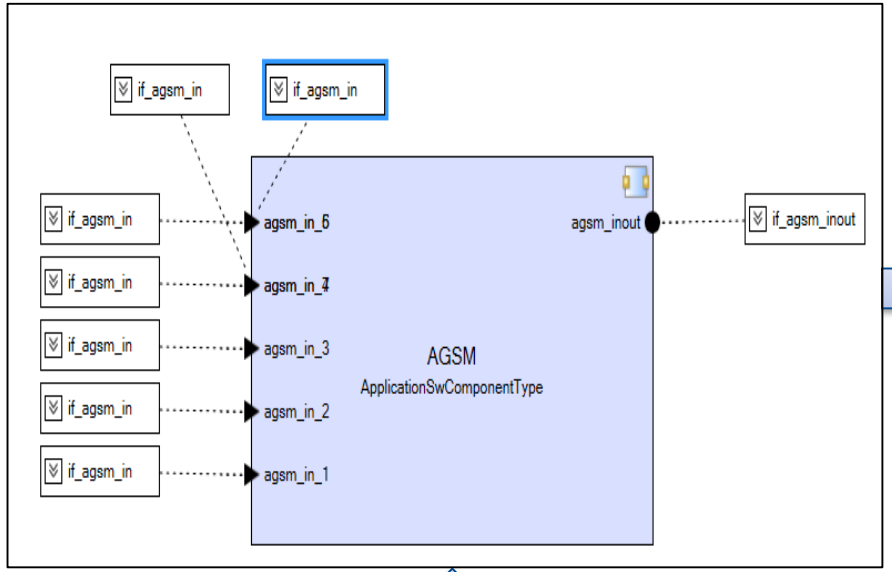

2 Import ARXML & Create Frame Model

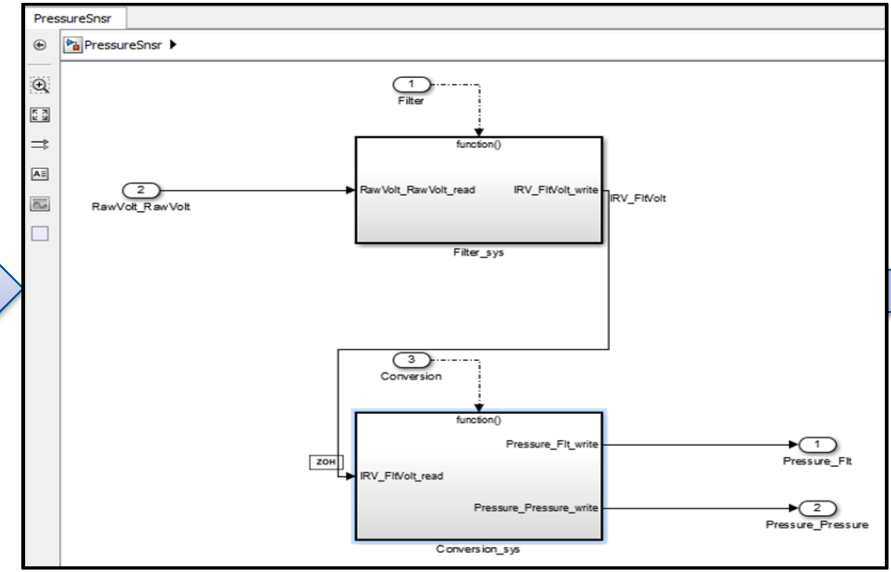

3 Update Detail logic

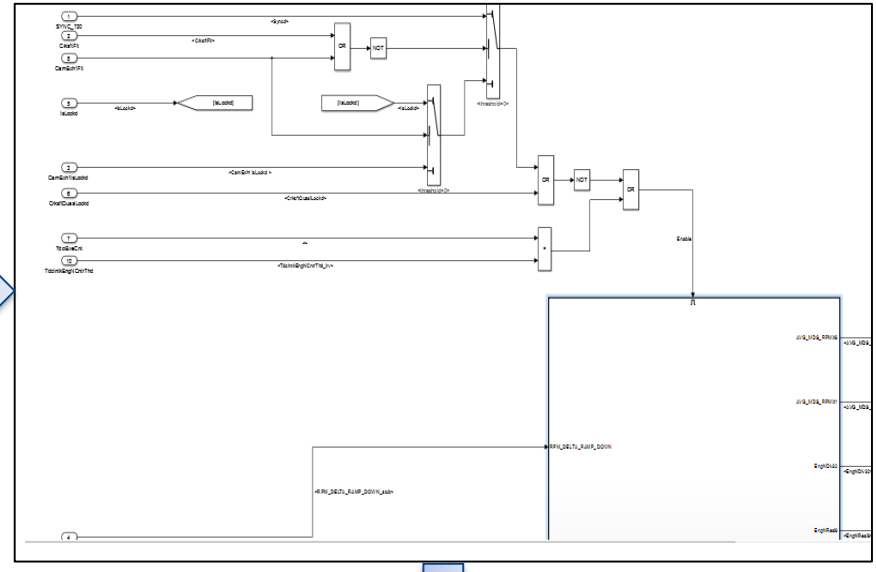

7 Merge ARXML

```
<APPLICATION-SW-COMPONENT-TYPE UUID="12f818e0-652f-49da-a179-7386630c580b">
  <SHORT-NAME>PressureSnsr</SHORT-NAME>
  <PORTS>
    <P-PORT-PROTOTYPE UUID="aad98a72-51c4-4826-8978-d227cod7eed2">
      <SHORT-NAME>Pressure</SHORT-NAME>
      <PROVIDED-INTERFACE-TREF DEST="SENDER-RECEIVER-INTERFACE"/>SharedElements/Interfaces/IF_Psnsr</PROVIDED-INT
    </P-PORT-PROTOTYPE>
    <R-PORT-PROTOTYPE UUID="6a33cf71-4c9b-47de-8933-227c34a1e186">
      <SHORT-NAME>RawVolt</SHORT-NAME>
      <REQUIRED-INTERFACE-TREF DEST="SENDER-RECEIVER-INTERFACE"/>SharedElements/Interfaces/IF_PImp</REQUIRED-INTER
    </R-PORT-PROTOTYPE>
    <R-PORT-PROTOTYPE UUID="acef5d51-bbd7-4a0c-b068-97ec5fbae4d4">
      <SHORT-NAME>DEMSERVICE</SHORT-NAME>
      <REQUIRED-INTERFACE-TREF DEST="CLIENT-SERVER-INTERFACE"/>Swcs/MySwc/Compositions/DEM_Services</REQUIRED-INTER
    </R-PORT-PROTOTYPE>
  </PORTS>
  <INTERNAL-BEHAVIORS>
    <SWC_INTERNAL_BEHAVIOR UUID="026e86cb-40de-4d35-0a00-8bc9f3cb95e9">
```

```
* Target selection: &#x2D;&#x2D;AUTOSAR-ILM
* Embedded hardware selection: 32-bit Generic
* Code generation objectives: Unspecified
* Validation result: Not run
*/

#include "Demo_Model_MultiRunnable.h"
#include "Demo_Model_MultiRunnable_private.h"

/* Exported data definition */
#define Config_Demo_Model_START_SEC_CONST
#include "Config_Demo_Model_MemMap.h"

/* Definition for custom storage class: Global */
const real_T EXH_TEMP_Stall_Value = 0.0;
const real_T SHUTDOWN_DEFAULT_Value = 10.0;

#define Config_Demo_Model_STOP_SEC_CONST
#include "Config_Demo_Model_MemMap.h"
#define Config_Demo_Model_START_SEC_VAR
#include "Config_Demo_Model_MemMap.h"

/* Definition for custom storage class: Global */
real_T TEMP_DELTA;

#define Config_Demo_Model_STOP_SEC_VAR
#include "Config_Demo_Model_MemMap.h"

/* Block signals (auto storage) */
B_Demo_Model_MultiRunnable_T Demo_Model_MultiRunnable_B;

/* Block states (auto storage) */
DW_Demo_Model_MultiRunnable_T Demo_Model_MultiRunnable_DW;
```

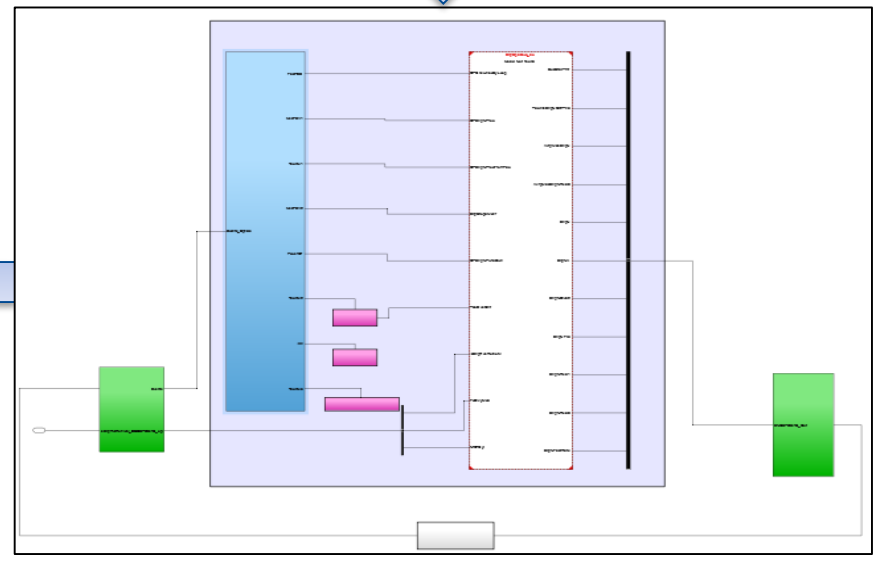

6 Generate ARXML

5 Generate Code & Preform SIL

4 Perform MIL Validation

Automotive Spice – Software Quality Assurance Standard

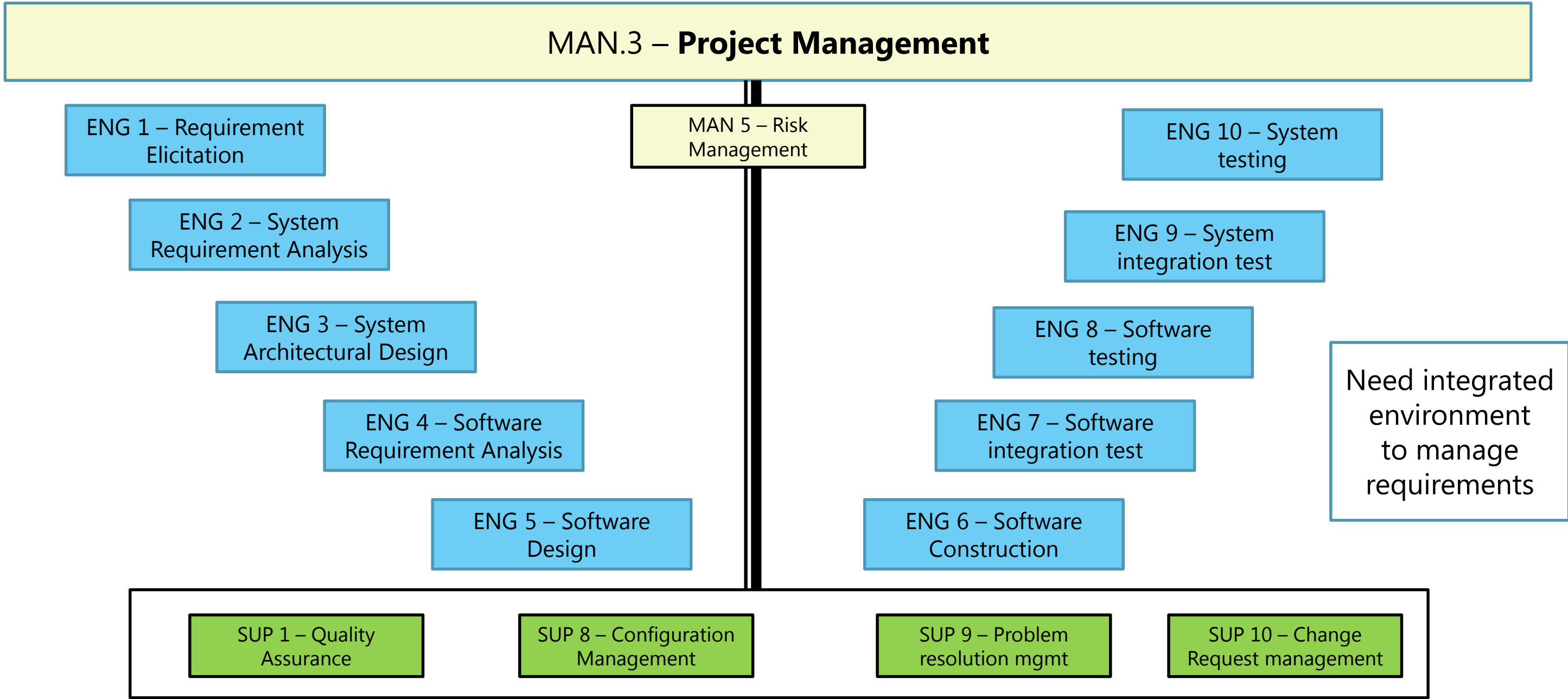



KPIT approach : Integrated tools environment for ASPICE compliant workflow

Requirements Management Tool

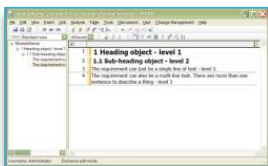

Architecture Modeling Tool



Systems and Controls Modeling Tool

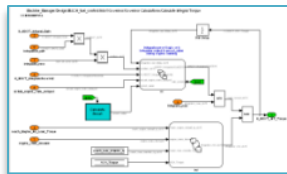

Auto-code Tool

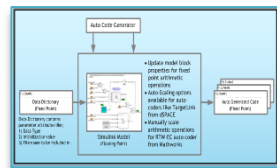

MIL/SIL/HIL Testing Tool

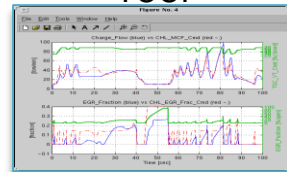

Objective:

- Allows management of product lifecycle development based on PLA principles
- Allows traceability throughout product development lifecycle
- Allows impact analysis across product lines and engineering artifacts
- Allows management visibility of the whole process
- Enable global collaboration
- Process and standards compliance (CMMI, AutoSpice, SAE, ISO 26262)

Engineering Workflow



Integrated Infrastructure

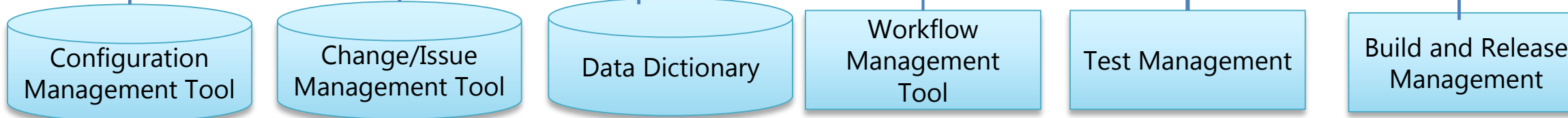

ALM Environment

- Model based development is way forward to develop Automotive controls software
- Model based development is well suited to develop controls software compliant to Automotive standards
 - ISO26262
 - ASPICE
 - Autosar
- Increasing electronics content in Automotive is increasing system complexity, needs many engineers with expertise in Model based development.

Our approach to meet demand - ECoDe – developing right talent to cater to customer demands

KPIT Learning Model

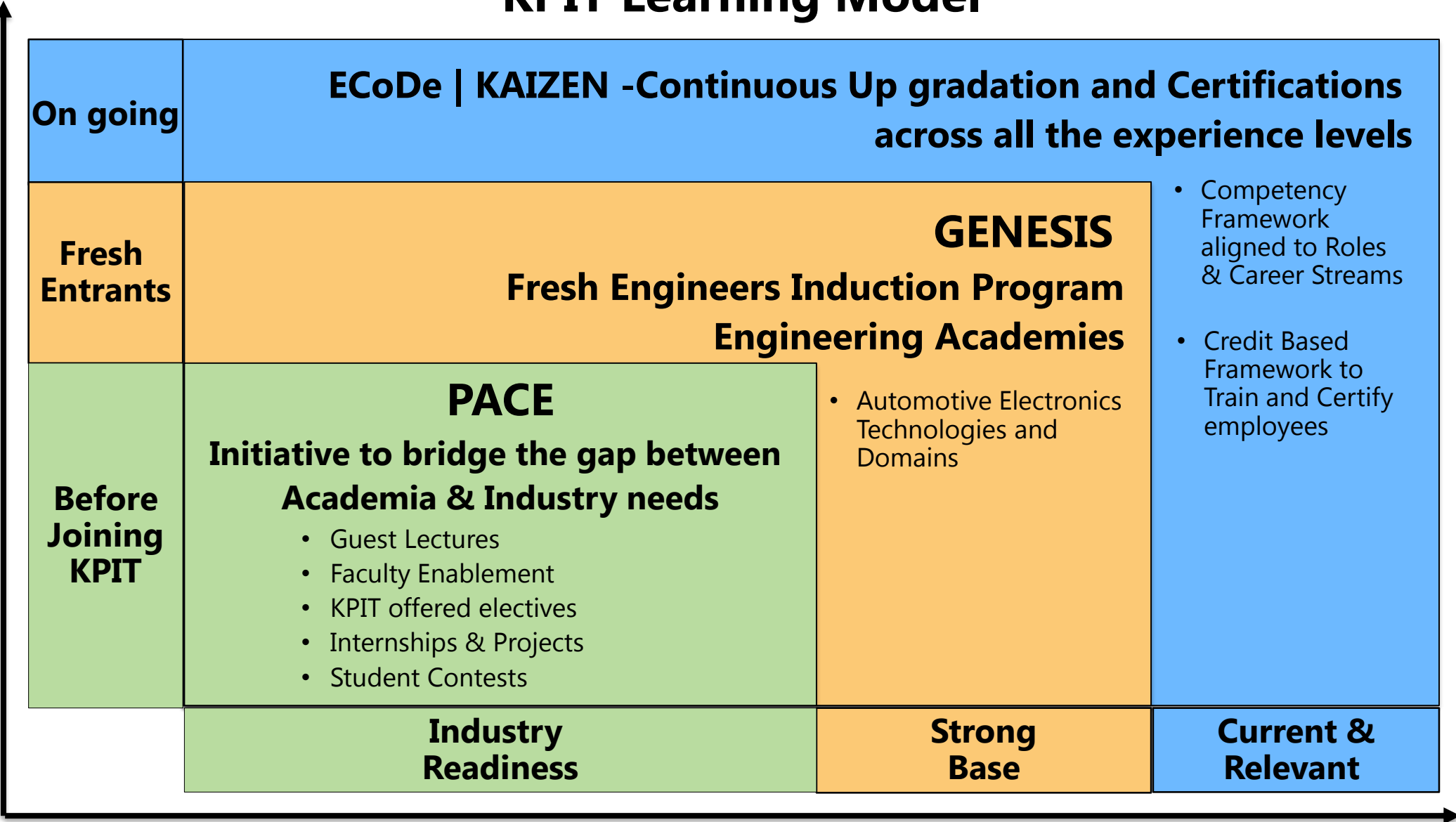

Collaborations with Internal Stake holders and External Partners

ELEVATE | LIFT | ASPIRE | SOFT SKILLS

Leadership Development Programs to mentor Emerging & Existing Leaders

40-40-20
Academy SME + KPIT SME + Vendor Partners Model
 Collaborative Education Model

GENESIS (6-8 weeks)
 Every Campus recruited engineer trained & ready for customer projects

PACE: Program for Academic Collaboration and Engagement

Program for Academic Collaboration & Engagement (PACE) & GENESIS

Unique Initiative of KPIT

Programme objectives

Build **KPIT Brand** in Universities / Institutions to attract the right talent

Hire the **Right motivated talent for each practice**

Quicker deployment on projects / reduce internal training time / costs / efforts

Representation on Academic boards of Institutions **To influence education System**

Work to create **Industry ready niche resources**

SBU Aligned fresher induction and deployment

Faculty Development through collaborations

1

"PACE" Programme partnership kit for academic institutions

2

MOUs with 20 Partner Institutions aligned to SBU needs

3

Standard education artifacts in partnership with SBUs & Academies and repositories

4

KPIT created courses approved by Academic boards and taught as part of Curriculum

5

Through "Train the Trainer" Faculty enablement programmes & exchange programmes **60+ faculty trained**

6

Joint partnership for deployment & support institutions

7

PACE linked to Campus hire, Internships and prospective employee engagement

8

Induction to SBUs and Accounts –additions skill gap trainings as per needs

Thank You

www.kpit.com

