



使用基于模型设计 开发机器人系统和应用

松山湖国际机器人研究院 张延亮

zhang.yl@xbotpark.com

搜救MH370



汽车安全驾驶：斯巴鲁-Eyesight



Subaru Eyesight

特斯拉电动汽车

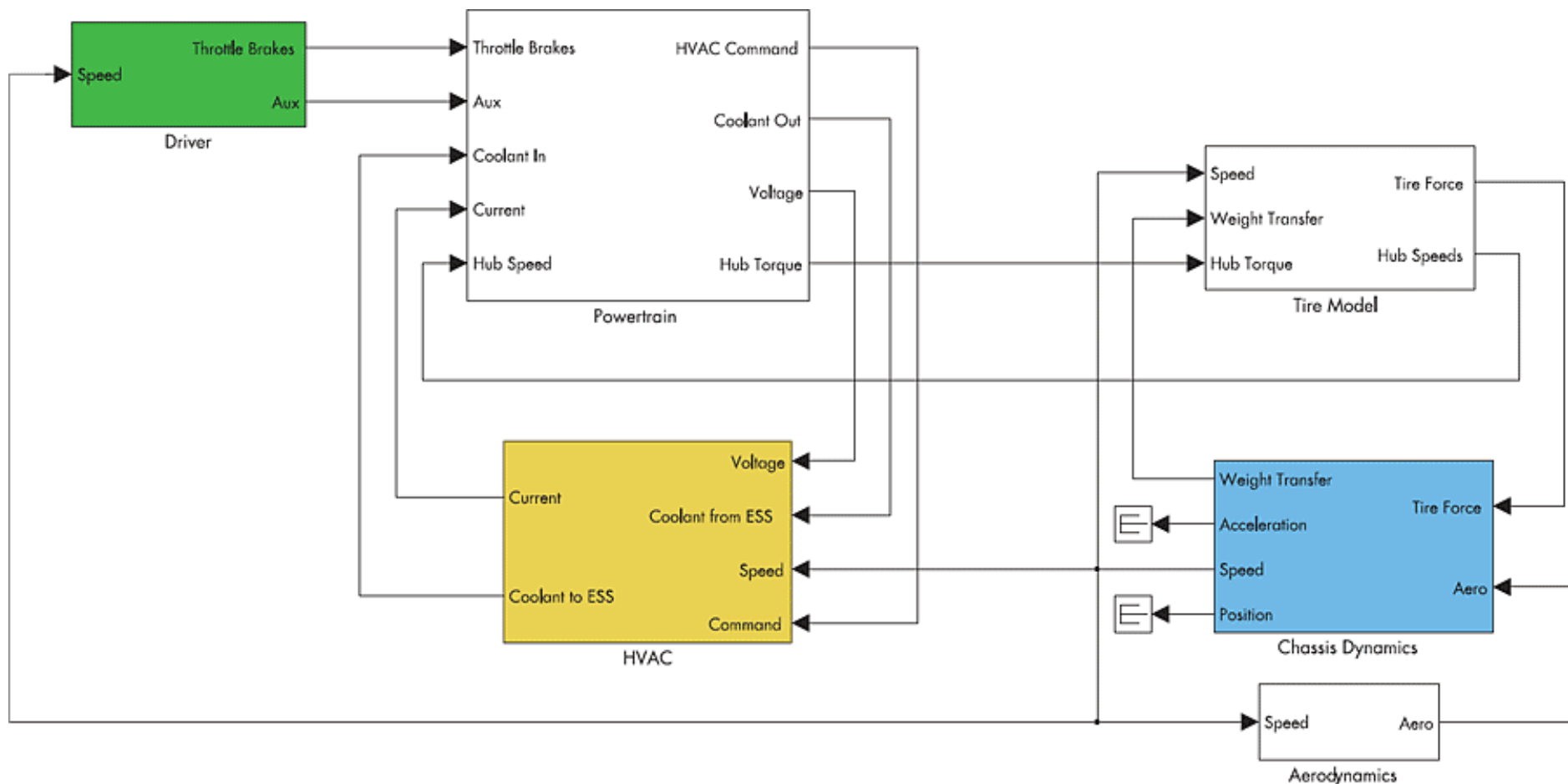

波士顿动力大狗



MIT猎豹



太空辅助机器人

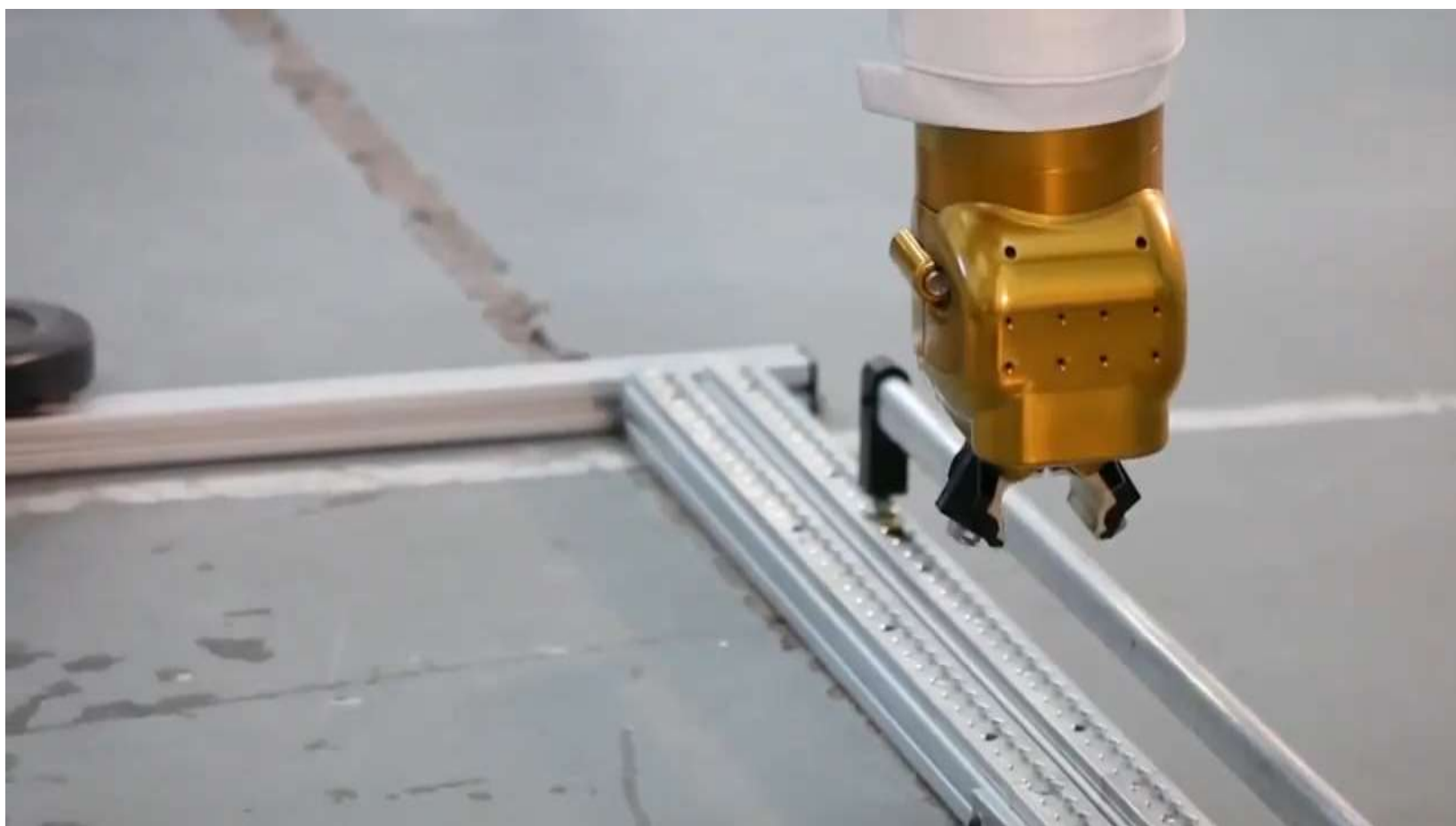

多自由度人形机器人



DLR Humanoid Robot Justin



Thought-controlled prosthetics

传统开发流程

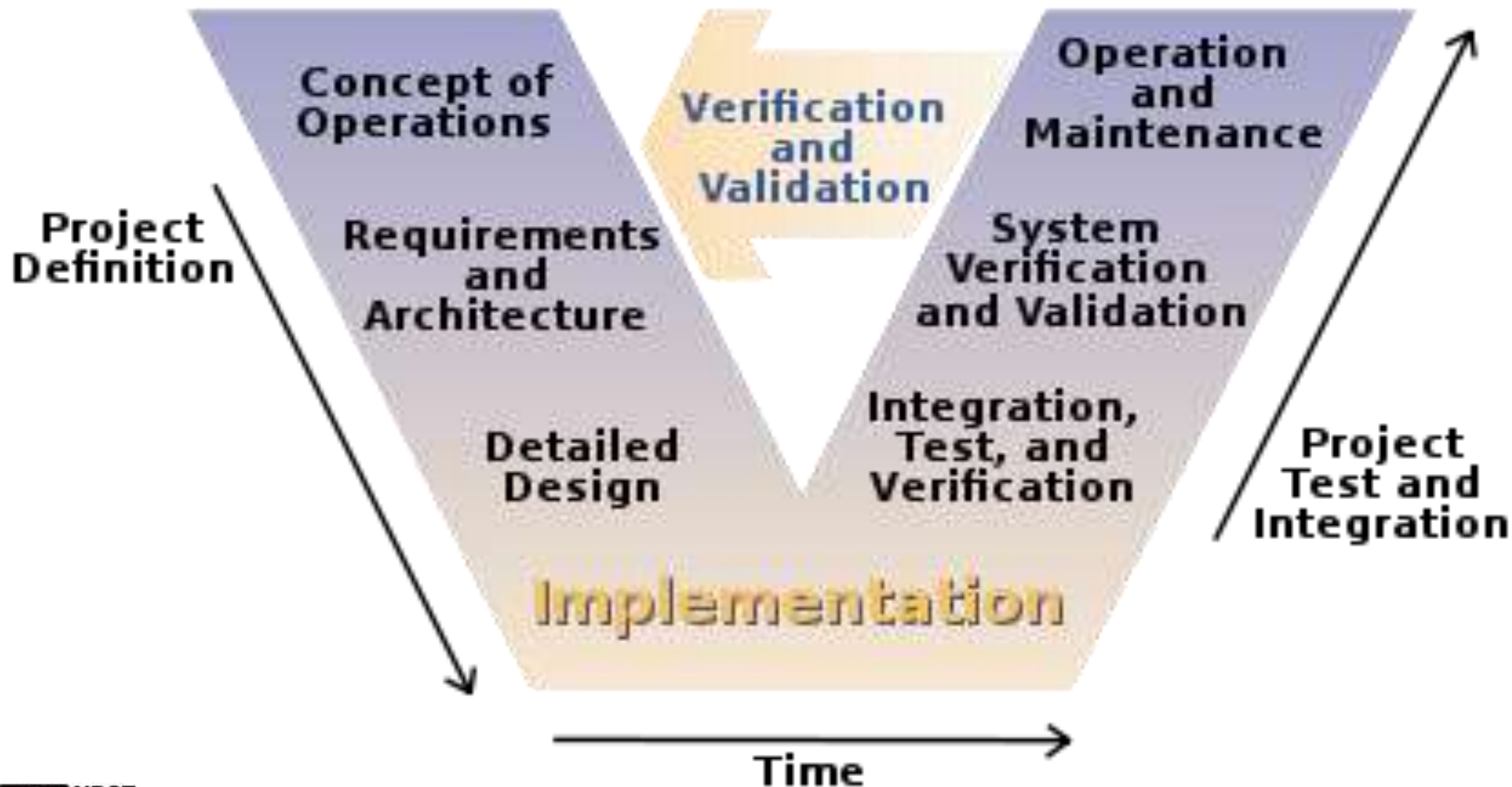

现代开发流程：基于模型设计

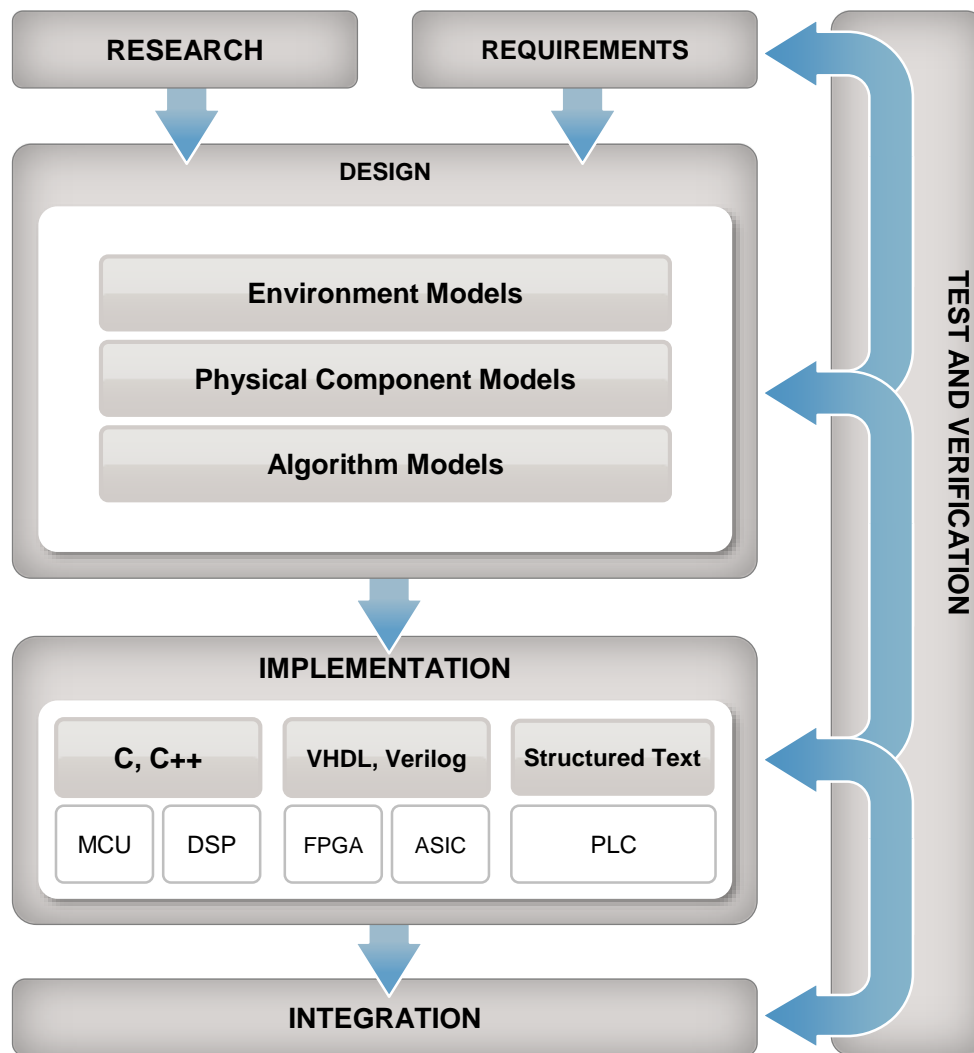
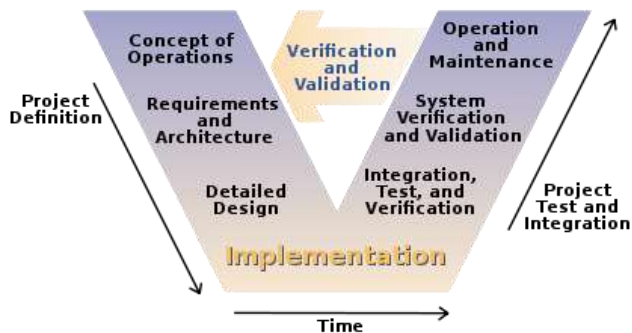

基于模型设计用在机器人领域

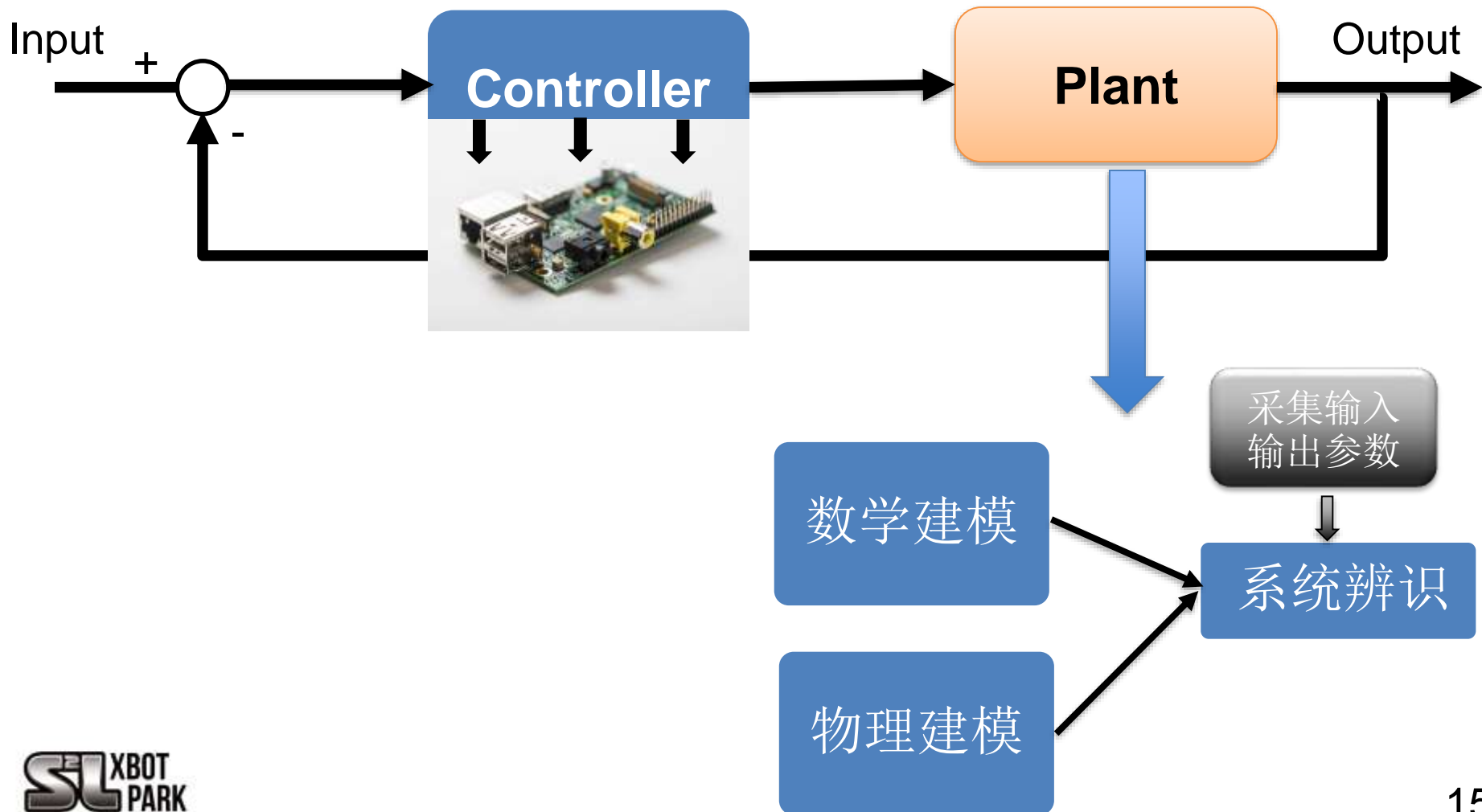

系统建模—数学/物理建模

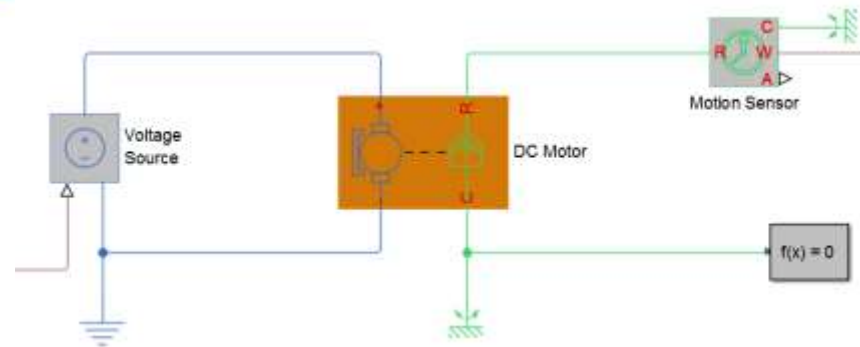
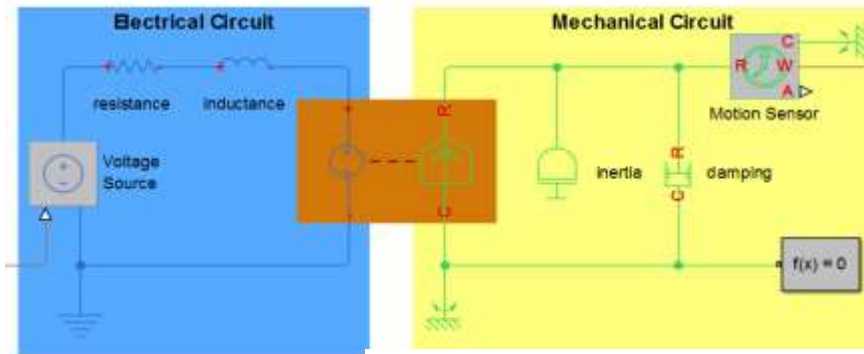
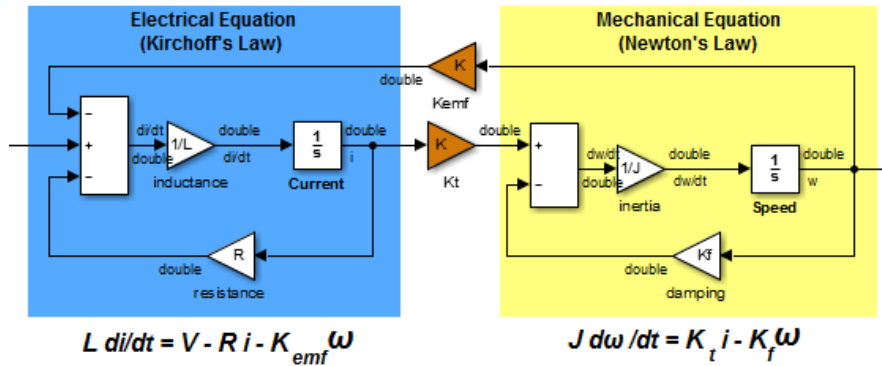

确定需要辨识的参数

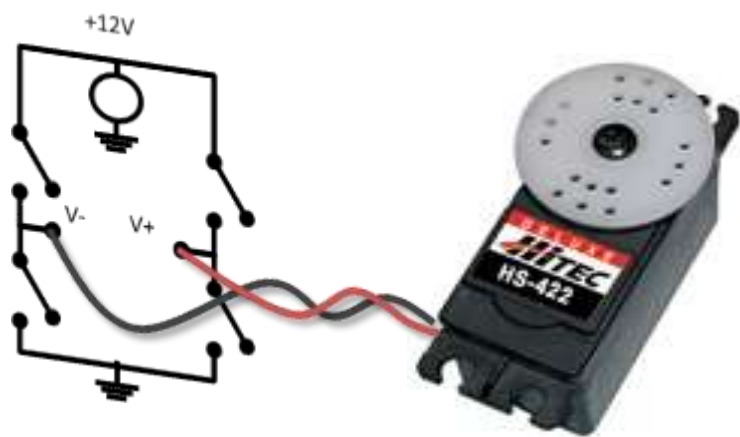

R = 电阻
 L = 电感
 J = 惯性负载
 K_f = 摩擦系数
 K = 反电势常数

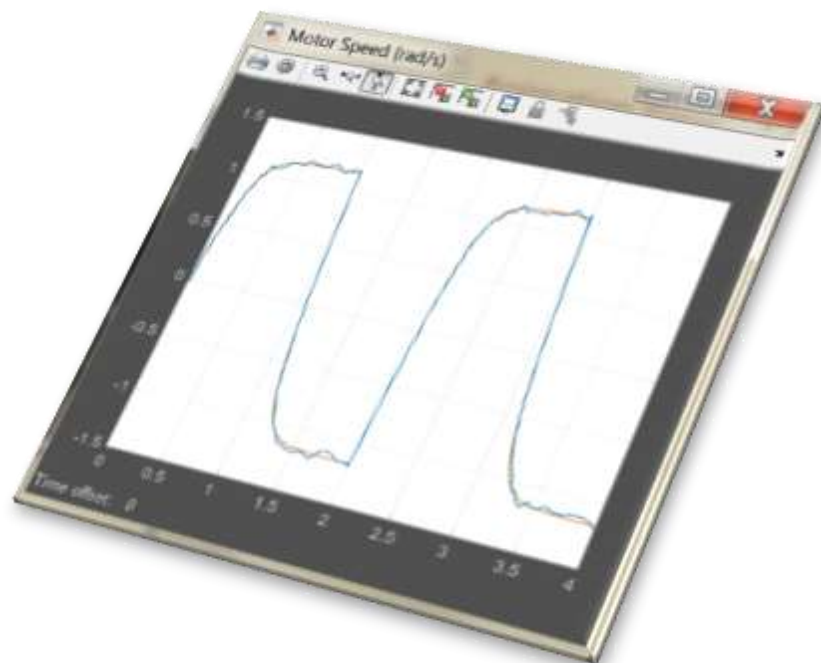

系统辨识—采集输入/输出

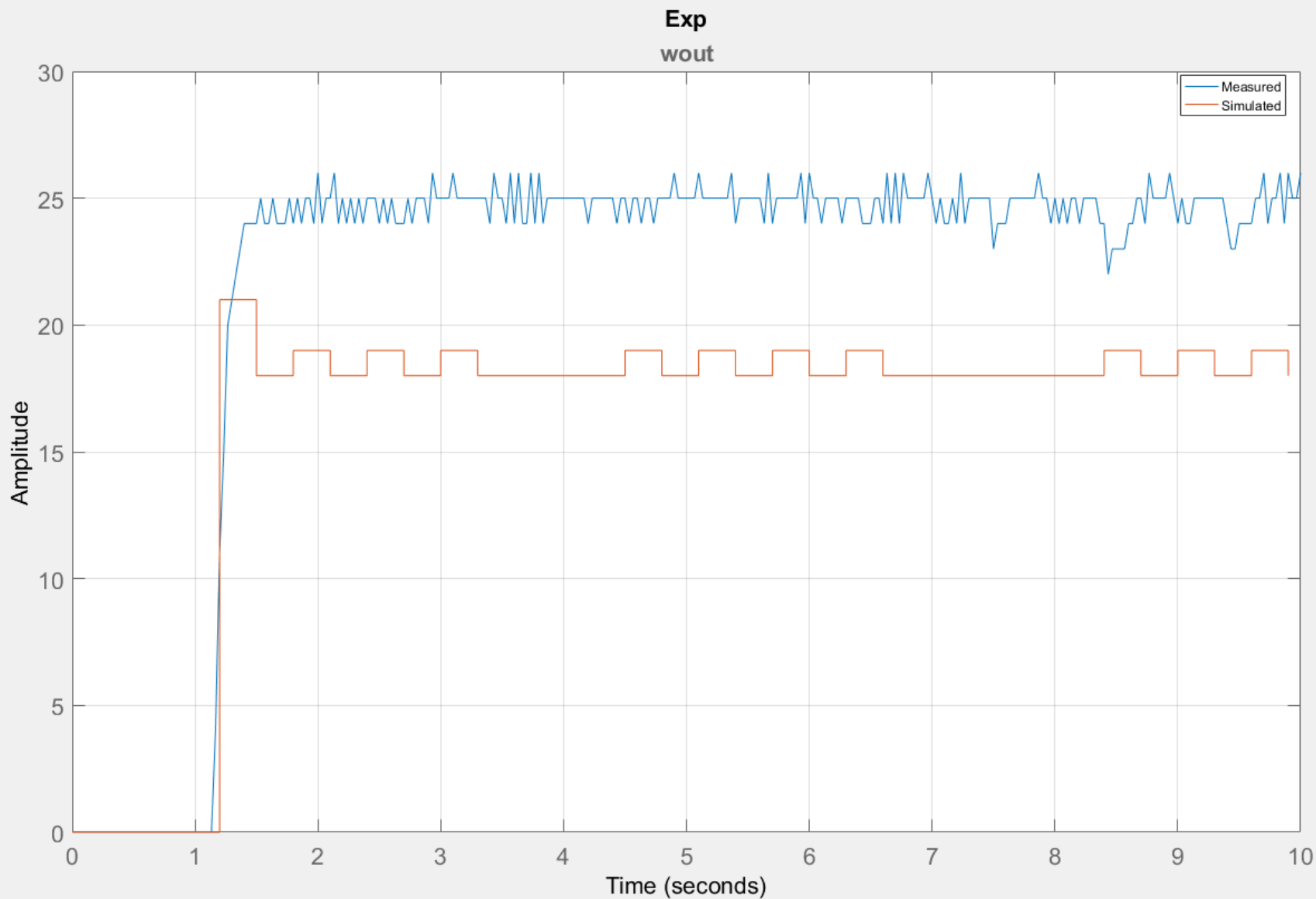

系统辨识—参数估计

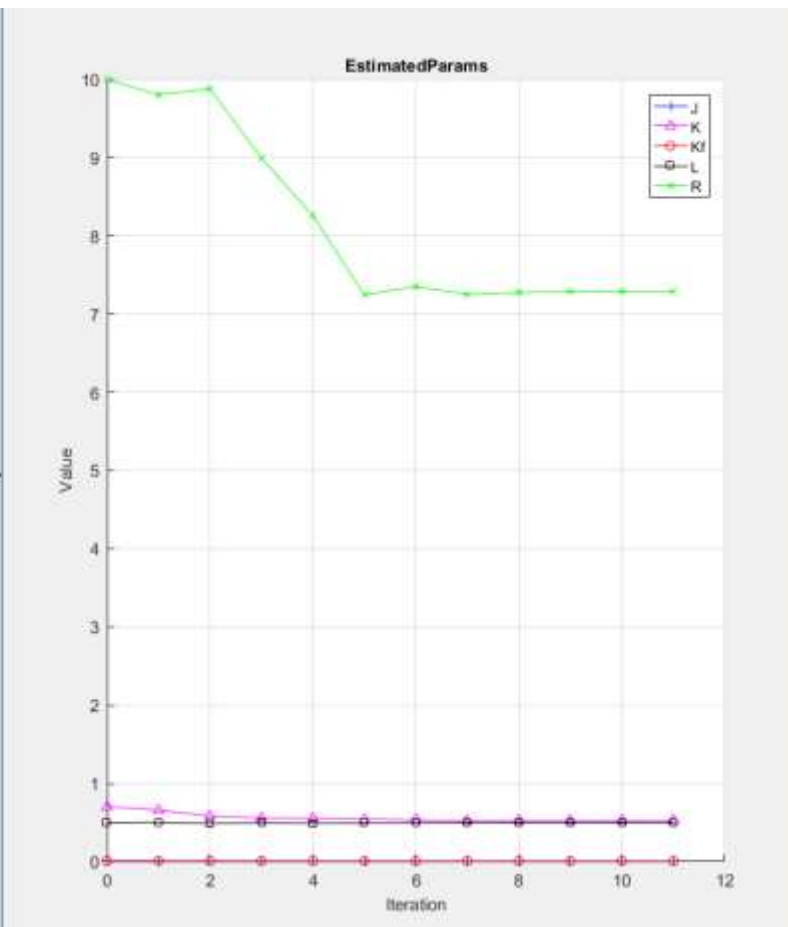
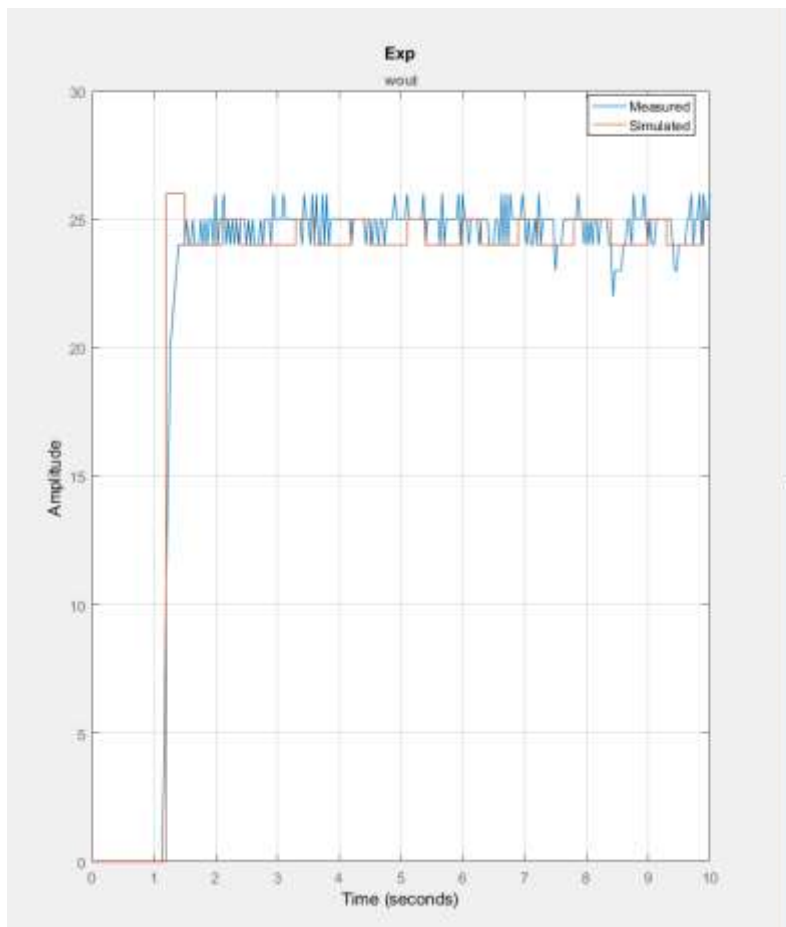

控制器的设计和优化

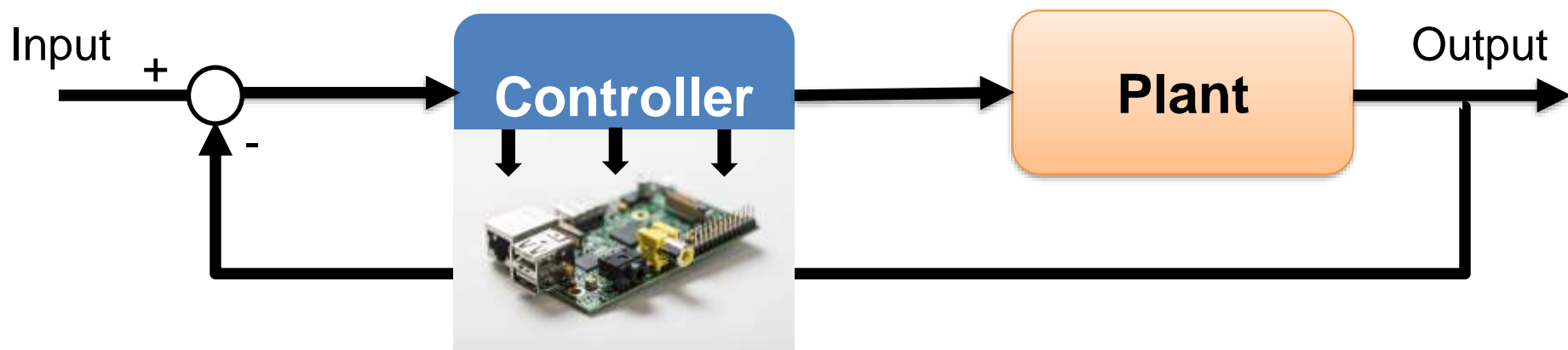

控制器的设计和优化

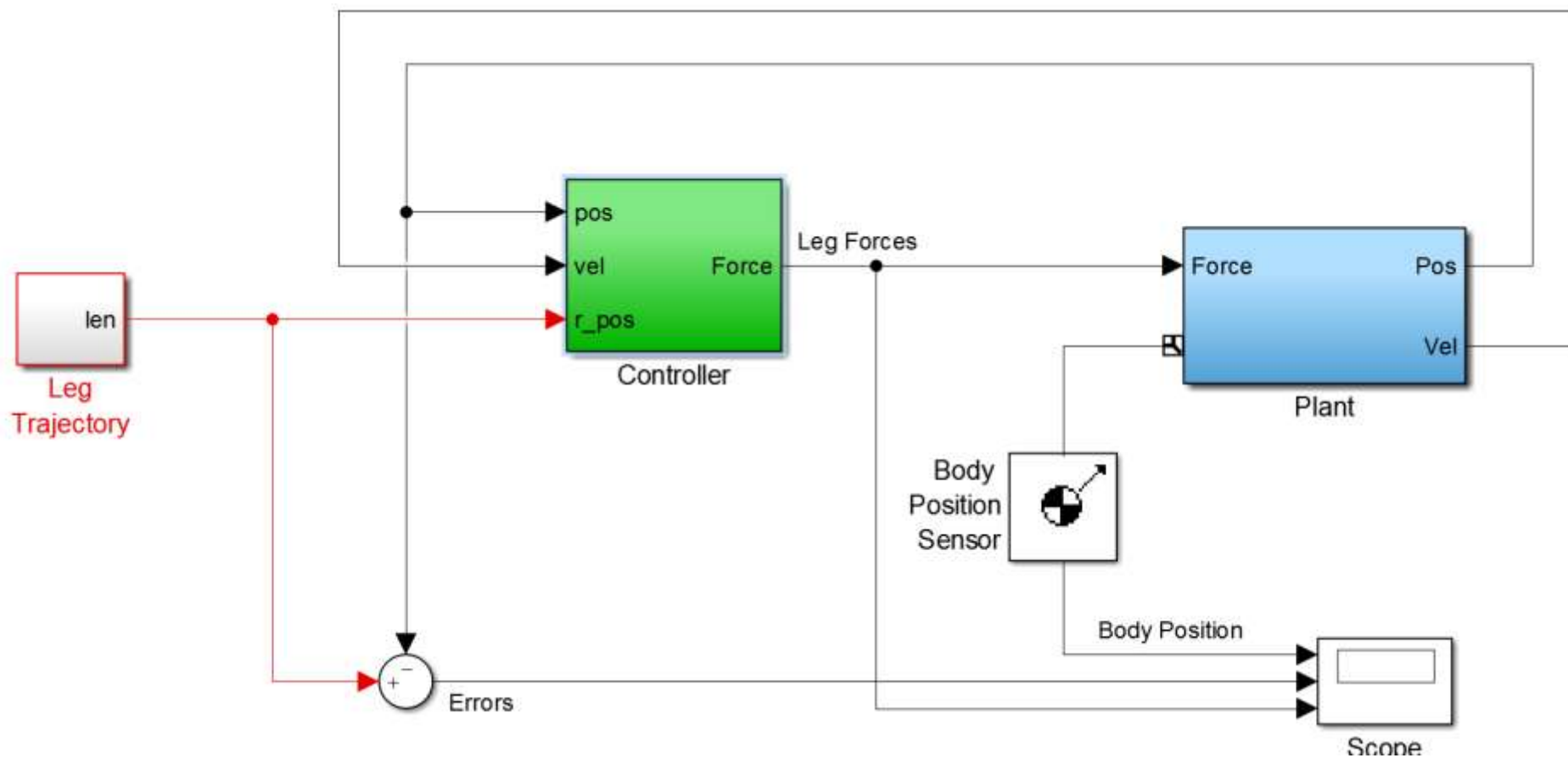

工业智能相机应用



The screenshot displays two Simulink windows. The left window, titled "Simulink Library Browser", shows a tree view of libraries. The right window, titled "JinLian_sobel_codegen", shows a Simulink model with a DSPBIOS task block connected to a function block.

Simulink Library Browser:

- File Edit View Help
- Enter search term
- Libraries
- FS_SIMVISION
 - FSvision algorithm
 - FS_OpenCV
 - FS_TI64x_IMGLIB
 - FSvision Sim_example
 - FSvision_CodeGeneration_example
 - Texas Instruments C6000
 - JinLian_AuMo_vision_robot1
 - JinLian_TMS320C6416 DSK
- Fuzzy Logic Toolbox
- HDL Verifier
- Image Acquisition Toolbox
- Instrument Control Toolbox
- Model Predictive Control Toolbox
- Neural Network Toolbox
- OPC Toolbox
- Real-Time Windows Target
- Report Generator
- Robust Control Toolbox
- SimEvents
- SimRF
- Simscape
- Simulink 3D Animation

JinLian_sobel_codegen:

- File Edit View Simulation Format Tools Help
- 10 Normal
- FS16_Target_Preferences_codegen
- Camera_30is Lib FS16_eSystem
- Out1 DSPBIOS task
- function() Machine Vision System
- Ready 100% FixedStepDiscrete

松山湖研究院其他应用案例：水下机器人

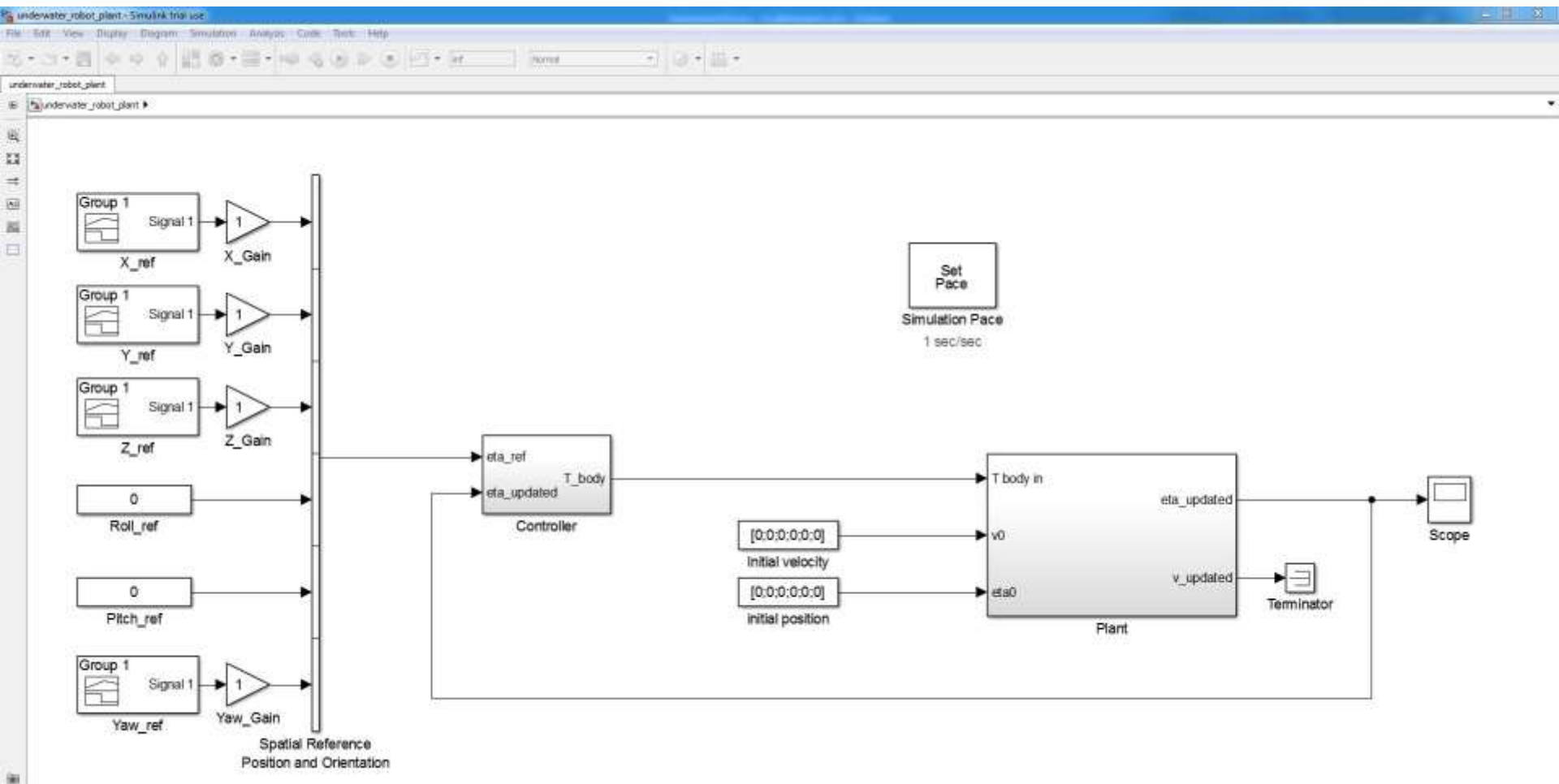

松山湖研究院其他应用案例：无人机阵列表演

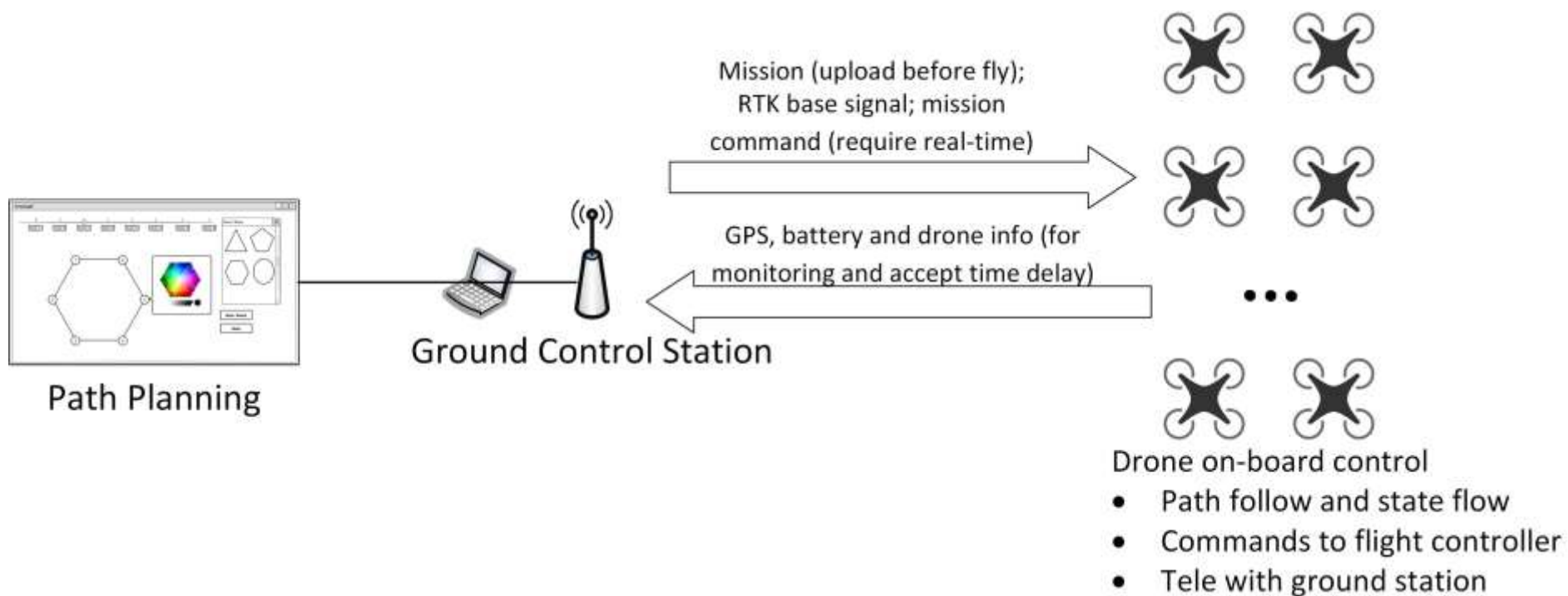

松山湖研究院其他应用案例：扫地机器人

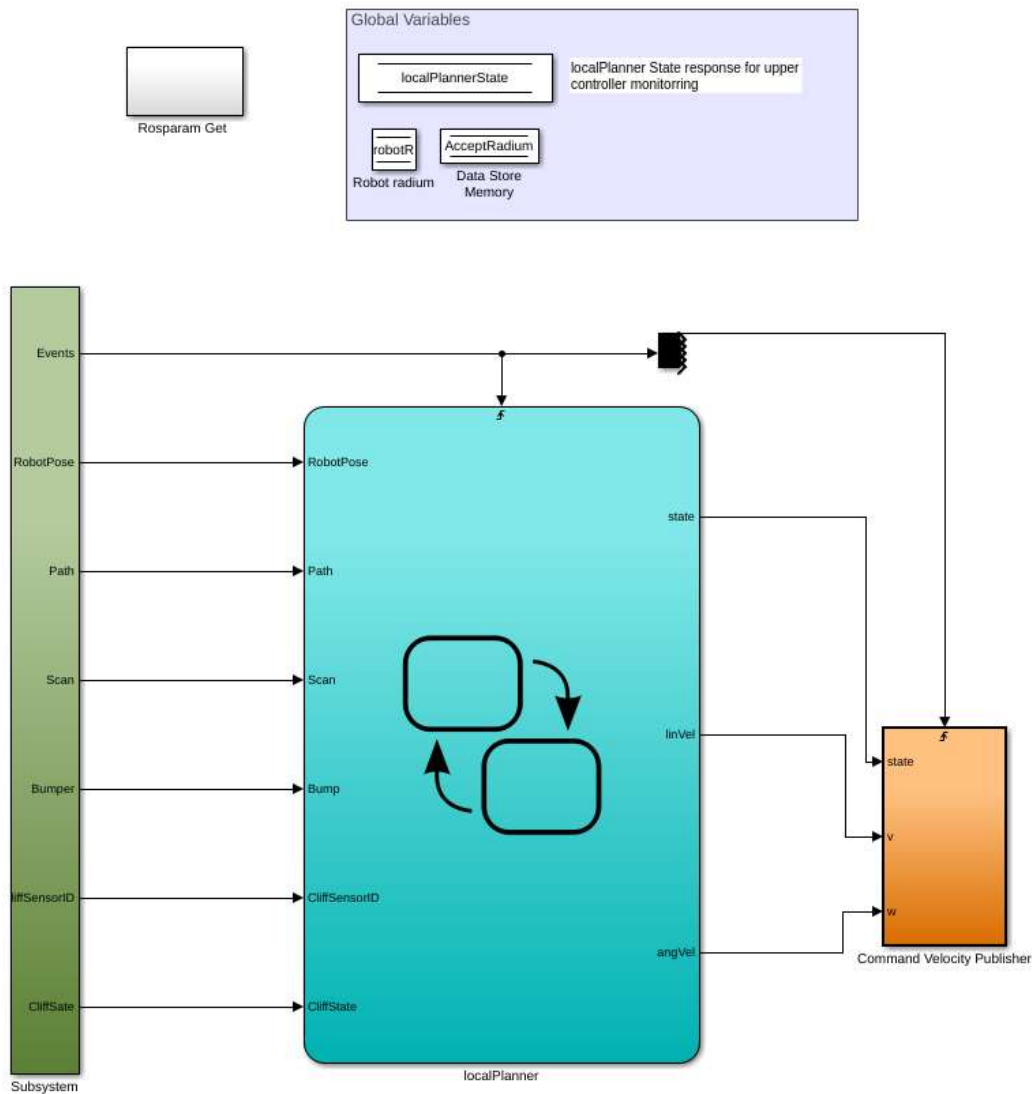

总结

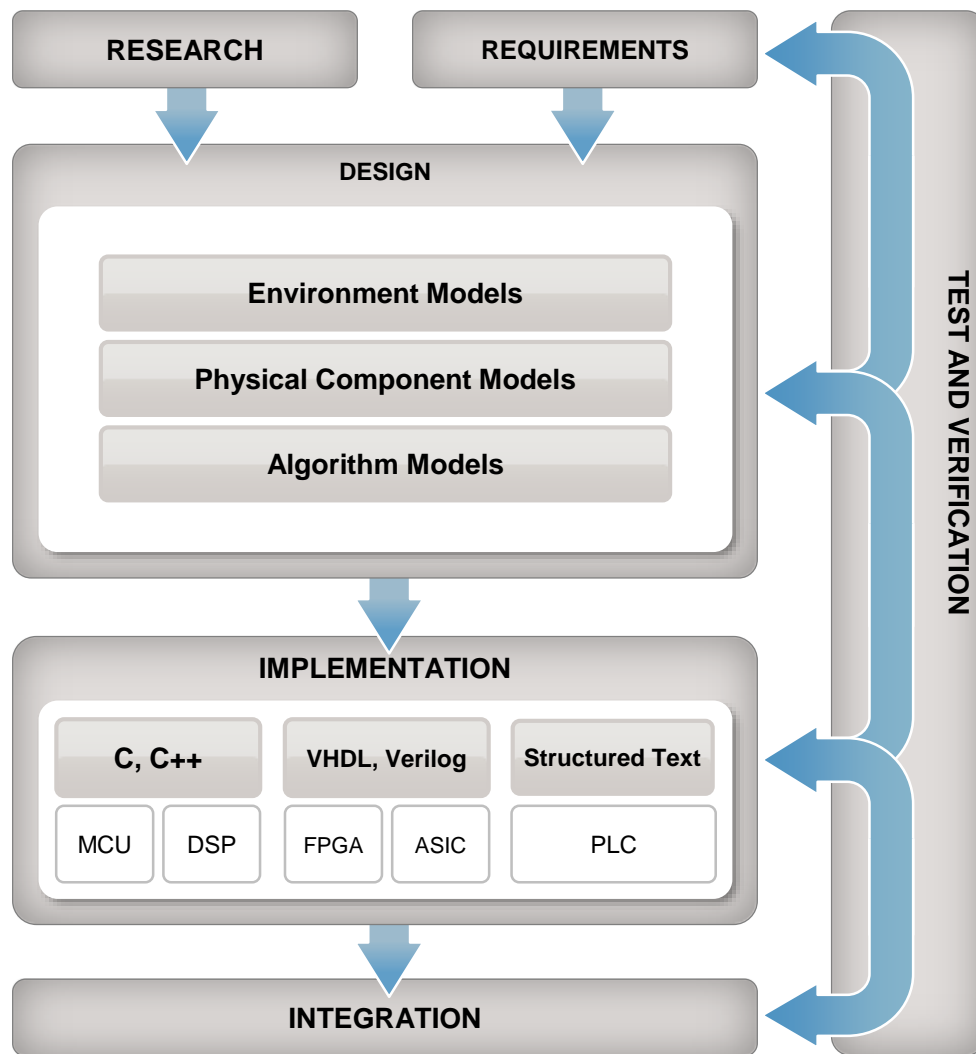

联系我们

东莞松山湖国际机器人研究院：

- 基于模型设计培训？
- 机器人方向创业？
- 加入现有创业团队？
- 和我们一起工作？



Liu.J@xbotpark.com



Zhang.YL@xbotpark.com

Baidu 百科